

Description	Hand-operated, spring-loaded high pressure regulator for maximum supply pressure of 220 bar and maximum outlet pressure of 200 bar. For outlet pressures up to 15 bar the regulator has a diaphragm, for higher outlets a piston. A sintered bronze filter at the inlet port protects against contamination.	
Media	compressed air or non-corrosive gases	
Supply pressure	max. 220 bar	
Adjustment	by hexagon head screw at RH3000-02 to -A3; T-handle at RH3000-06 to -10, with locknut	
Gauge port	All regulators are equipped with both one supply pressure gauge and one outlet pressure gauge.	
Safety relief valve	prevents from overpressure, see chart	
Compensation	All regulators are equipped with supply pressure variation compensation, so that a change in supply pressure has no effect on the outlet pressure's stability.	
Temperature range	-20 °C to 60 °C / -4 °F to 140 °F	
Material	Body: stainless steel 316 Diaphragm: stainless steel 316 O-ring: FKM / PTFE	Mounting position any Filter: stainless steel 316 Valve seat: FKM Piston: stainless steel 316

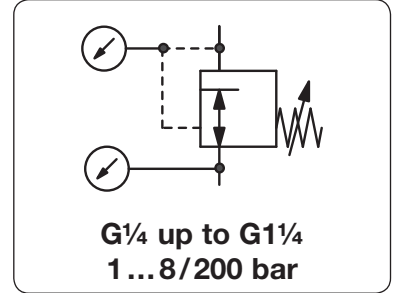

Dimensions			Safety relief valve	K _v -value	Flow rate	Connection thread	Pressure range	Order number
A	B	C	S: with valve	(m ³ /h)	m ³ /h*1	inlet/outlet	bar	

High pressure regulator 220 bar							non-relieving, for compressed air with supply and outlet pressure gauges	RH3000	
177	159	32	S	0.05	30	500	DIN 477 / G _{1/4}	1 ... 8	RH3000-02A
			S		45	750		1 ... 15	RH3000-02B
177	173	32	S	60	1000			3 ... 30	RH3000-02C
			S	60	1000			5 ... 50	RH3000-02D
			S	60	1000			10 ... 100	RH3000-02E
			-		60	1000		20 ... 200	RH3000-02F
190	169	40	S	0.15	70	1150	DIN 477 / G _{3/8} m	1 ... 8	RH3000-03A
			S		155	2580		1,5 ... 15	RH3000-03B
			S	210	3500		DIN 477 / G _{3/8}	3 ... 30	RH3000-03C
190	174	40	S	250	4100			5 ... 50	RH3000-03D
				350	5800			10 ... 100	RH3000-03E
			-		390	6500		20 ... 200	RH3000-03F
182	239	40	S	0.25	370	6170	DIN 477 / G _{1/2} m	1 ... 15	RH3000-A3B
182	243	40	S		460	7700	DIN 477 / G _{3/8}	3 ... 30	RH3000-A3C
			S		650	10830		5 ... 50	RH3000-A3D
					680	11300		10 ... 100	RH3000-A3E
182	194	40	-		700	11670		20 ... 200	RH3000-A3F
171	342	227	S	1.5	600	10000	G _{3/4} m / G _{3/4} m	1 ... 8	RH3000-06A
			S		720	12000		1 ... 15	RH3000-06B
171	363	248	S		850	14170		3 ... 30	RH3000-06C
			S		1000	16670		5 ... 50	RH3000-06D
			S		1050	17500		10 ... 100	RH3000-06E



RH3000-02



RH3000-03

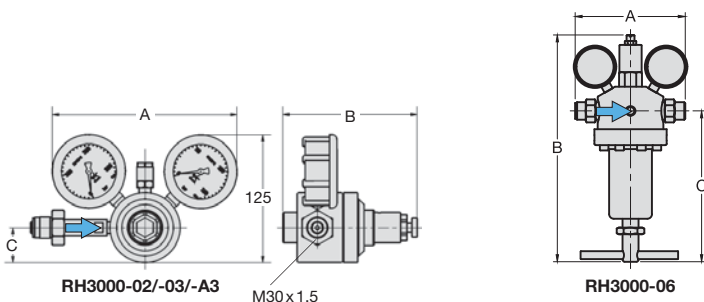
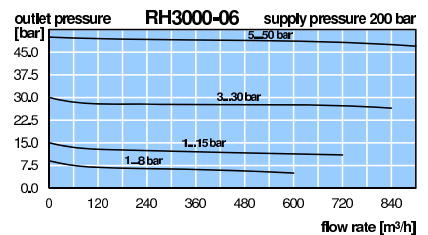
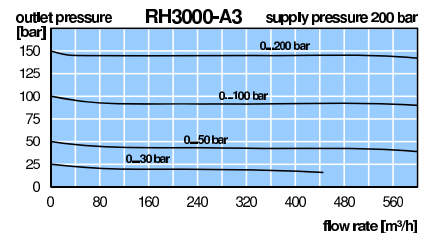
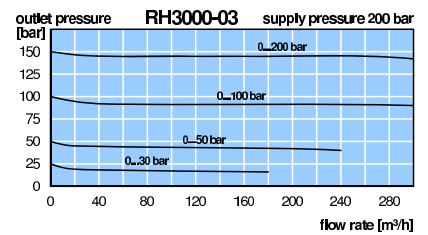

*1 at 200 bar supply pressure and max. outlet pressure

Stainless Steel High Pressure Regulator, P₁: up to 200 bar

RH3000

Description	Hand-operated, spring-loaded high pressure regulator for maximum supply pressure of 220 bar and maximum outlet pressure of 200 bar. For outlet pressures up to 15 bar the regulator has a diaphragm, for higher outlets a piston. A sintered bronze filter at the inlet port protects against contamination.		
Media	compressed air or non-corrosive gases		
Supply pressure	max. 220 bar		
Adjustment	by hexagon head screw at RH3000-02 to -A3; T-handle at RH3000-06 to -10, with locknut		
Gauge port	All regulators are equipped with both one supply pressure gauge and one outlet pressure gauge.		
Safety relief valve	prevents from overpressure, see chart		
Compensation	All regulators are equipped with supply pressure variation compensation, so that a change in supply pressure has no effect on the outlet pressure's stability.		
Temperature range	-20 °C to 60 °C / -4 °F to 140 °F		
Material	Body: stainless steel 316	Filter: stainless steel 316	Mounting position any
	Diaphragm: stainless steel 316	Valve seat: FKM	
	O-ring: FKM / PTFE	Piston: stainless steel 316	

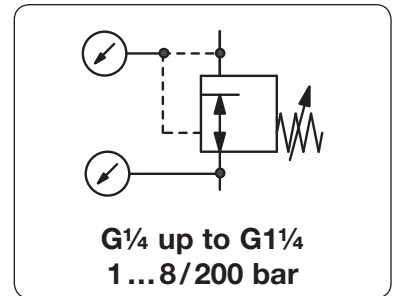

Dimensions			Safety relief valve	K _v -value	Flow rate	Connection thread	Pressure range	Order number
A	B	C	S: with valve	(m ³ /h)	m ³ /h* ¹	inlet/outlet	bar	

High pressure regulator 220 bar								non-relieving, for compressed air with supply and outlet pressure gauges	RH3000
250	371	243	S	2.5	1100	18330	G1 m/G1 m	1 ... 8	RH3000-08A
			S			1300		1 ... 15	RH3000-08B
250	410	282	S	1500	25000			3 ... 30	RH3000-08C
			S	1650	27500			5 ... 50	RH3000-08D
250	390	262	-	1850	30830			20 ... 200	RH3000-08F
246	388	272	S	3.5	3850	65830	G1 m/G1 1/4	1 ... 15	RH3000-10B
246	429	313	S	3500	58330			10 ... 100	RH3000-10E



RH3000-08



RH3000-10

Special options, add the appropriate letter

diaphragm relieving		RH3000-... R
piston relieving		RH3000-... R
EPDM elastomer		RH3000-... E
for panel mounting	for RH3000-02 to -A3	RH3000-... P
carbon dioxide* ²	CO ₂	RH3000-... 03
argon	Ar	RH3000-... 05
nitrogen	N ₂	RH3000-... 07
helium	He	RH3000-... 09
hydrogen	H ₂	RH3000-... 11
methane	CH ₄	RH3000-... 13
natural gas * ³		RH3000-... 14
propane	C ₃ H ₈	RH3000-... 16
nitrous oxide	N ₂ O	RH3000-... 17



Accessories

mounting bracket	for RH3000-02	BW45-03S
mounting nut	for RH3000-02	M45x1,5S
mounting bracket	for RH3000-03 and -A3	BW50-01S
mounting nut	for RH3000-03 and -A3	M50x1,5S
mounting bracket	for RH3000-06	BW00-31S
	for RH3000-08	BW00-35S

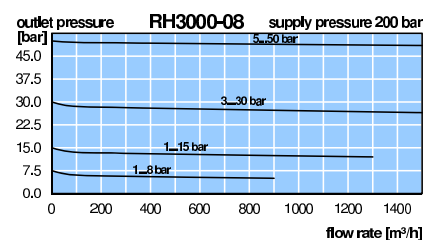
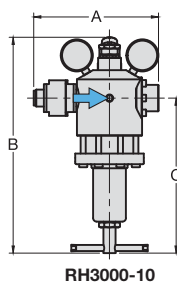
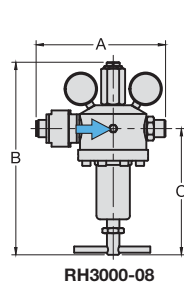

*1 at 200 bar supply pressure and max. outlet pressure

*2 max. 80 bar

*3 without DVGW-approval

